

---

# KALKOMAT

---

Kick Force Measuring Machine

## Technical Information



**KICK-OFF**



**KICKER**

**MANUFACTURED BY:**

**KALKOMAT**

**30-723 Kraków**

**Ul. Golikówka 4**

**POLAND**

***WWW.KALKOMAT.COM***

# INDEX:

<i>1. Introduction</i>	3
<i>2. Usage / Purpose</i>	3
<i>3. Technical Data</i>	3
<i>4. Assembly / Construction description</i>	4
<i>5. Transport</i>	4
<i>6. Installation</i>	5
<i>7. Usage instructions</i>	5
<i>8. Fixing potential errors</i>	5
<i>9. Quick check for potential errors.</i>	13
<i>10. Settings</i>	15
<i>11. Spare parts and equipment</i>	27
<i>12. Step by step setup and maintenance instructions</i>	28

## 1. INTRODUCTION

Main purpose of this Technical Information is to:

- familiarize user with machine construction
- provide proper setup parameters, installation and power line hookup
- familiarize user with proper and safe usage procedures, exploitation and conservation

**WARNING! USER MUST FOLLOW ALL GUIDELINES INCLUDED IN THIS DOCUMENT FOR SAFE AND LONG LASTING MACHINE USAGE.**

## 2. USAGE / PURPOSE

The Kicker and Kick-Off are a coin operated machines testing of how hard a player can kick the ball. Each Kicker model measure kick power and force. Kicker's can be placed in amusement centers, lunaparks, pubs, bars, bowling centers, young and senior clubs etc. generating tons of positive fun and allowing users to check/measure their kicking skills without potential injury to players. How to play: traditional arcade game requiring to kick strongly to get the highest score. Complete and detail usage instructions are under paragraph 7 of this document (see "Exploitation") and on a sticker placed on each machine.

## 3. TECHNICAL DATA

Model		Kick-Off	Kicker
Dimensions	Depth	60 cm / 23,64"	84 cm / 33"
	Width	110 / 43,34"	143cm / 56"
	Height	200cm / 78,8",	175 cm / 69"
Overall Mass		100 kg / 220,5 lb	140 kg /309 lb
Power consumption		200 [Wh]	200 [Wh]

#### **4. ASSEMBLY / CONSTRUCTION DESCRIPTION**

The key component is a mother board (electronic board) placed inside Kicker and Kick-Off bodies (block schematics drawing #1) to which mechanical elements and user interface components are connected.

Electric/electronic part contains following:

- power supply (drawing #3) – consists of transformer, fuses and broadcasters that control alarm sirens & electromagnet – transforms voltage from 120 V or 230 V (depending on the country) to 12 V (connected to main board J6),
- measuring mechanism – consists of sending and receiving diodes that measure blade fly speed through assembly,
- verbal information mechanism – built using potentiometer and speaker, used to send voice messages warning siren (informs player of breaking top record),
- kicking ball lowering mechanism – consists of button START with backlight and electromagnets – actual lowering mechanism,
- power supply switch on also halogen lamp,
- visual information assembly - displays on electronic panel (shows measurement result, credit amount, top day record – see drawing #2) and line of LED's used for visual representation of kick force measurement (represented in Kick-Off model),
- coin acceptor – used to deposit coins (can be reprogrammed to tokens or other currencies),
- bill acceptor – used to deposit bills,
- mother board.

#### **5. TRANSPORT**

Machines are shipped on wooden palette and sides are covered with special thick (~12 mm) multi-layer cardboard.

## 6. INSTALLATION

Machine after being taken out of the box should be placed in vertical position and base should be leveled. To level the machine correct tools should be used (exp. laser level or typical manual construction heavy duty level). Turning several screws under the base allows for level adjustment. After plugging the machine to power outlet it should be ready to use.

## 7. USAGE INSTRUCTIONS

- a) Before pressing the "START" button player must stand in the front of the Kicker/Kick Off,
- b) After pressing the "START" button player has to wait in front of the machine for the kicking ball to be released from the blocked position,
- c) After the kicking ball is released player must kick the ball in the center of the ball,
- d) After the kick, a score would be displayed on the front panel,
- e) Follow the same instructions before the next game.

## 8. FIXING POTENTIAL ERRORS

### EVERY TWO WEEKS:

- if using the leather ball with inner bladder, check the air pressure of the bag. It should be **no more** than 2psi,
- check the position of the arm protector,
- check all of the connections on the main board,
- check the level/balance of the machine. If needed use adjusting legs under the machine to bring the machine to level.

### EVERY MONTH:

- check mounting cover screws/nuts,
- check the lubrication of the mechanism. For the instructions see point C in this section,
- check the display lights,

- clean the bill acceptor.

#### **A) COIN ACCEPTOR MAINTENANCE**

Coin acceptor should be cleaned periodically (every 2000 - 3000 credits). Best way to clean it is by using simple cloth slightly soaked in distilled alcohol. Focus should be placed on cleaning the area where coins slide through (make sure sliding part is in open position).

#### **B) SOUND VOLUME REGULATION**

R362 potentiometer (see drawing #1) used to control volume is placed on the right side of the electronic board. The volume adjustment can be done by rotating the potentiometer to the left or right.

#### **C) MAINTENANCE OF MECHANISM AND REGULATING SPRING**

Periodically (once a month or more often, if the lowering ball mechanism of the ball is fairly low) all moving elements should be rubbed/sprayed with WD-40 or grease.

If kicking ball lowers slowly or too fast one should check if spring is properly stretched. Spring can be adjusted with screw that is in the front/left side after taking the masking net.

#### **D) FUSES REPLACEMENT**

Machine is equipped with two long term fuses. One at power supply assembly and the second one on the main electronic board [specs: 250V & 4 A]. In case of short circuit situation and/or insufficient power supplied to the electronic main board one should first check the fuses and if they are burned, precede with replacement set. Make sure fuses used to replace old one have the same specifications.

## E) BALL REPLACEMENT

### 1. Spare set



### 2. Mark the middle of the arm



3. Drill a hole in the middle of arm **it's necessary.**



4. If there is a screw in the middle of the ball between other 3 screws, unscrew the middle one.

5. Place the ball into the arm.



6. Prepare screw from spare set (or the one you unscrew in point 4).



7. Screw in prepared screw into the middle hole.



8. Use spanner nr 13.



9. Screw in from the outside of the arm.



10. Screw in so far that 3 ball screws can be seen outside of the arm.



11. Using spanner 13 screw in 3 screws from the ball.



12. **IMPORTANT!** Take out the screw from the middle of the arm.



13. Job done. New ball is ready.



## **9. QUICK CHECK FOR POTENTIAL ERRORS.**

### **Main board not functioning:**

- 1 Check all fuses (5A).
- 2 Check connection between power supply and the main board.
- 3 Make sure that main processor and other connectors are well seated.
- 4 The main display can be checked by turning the switch #1 to “ON” position than turning machine off and back on.

### **Coin Acceptor is not functioning:**

- 1 Check if it is not clogged up.
- 2 Check for dust and dirt.
- 3 Check strip connecting main board with the acceptor.

### **Mechanism is not functioning:**

- 1 Check for burned fuse 25A (in power supply [red cable]).
- 2 Check button functionality and if they have proper connection.
- 3 Check for unhooked cable from power supply spools.
- 4 Check strip connecting main board with the power supply.

### **Sensor is not functioning:**

- 1 Check sensors in service mode (using switch 1 and manipulating switch SW1) go to mode PO7. In Kick Off model if is moving UP/DOWN and on the main board (depending on ball position) HI – LO shows (this would indicate that sensor is working)  
In Kicker model if is moving LEFT/RIGHT and on the main board (depending on ball position) HI – LO shows (this would indicate that sensor is working).
- 2 Check if sensor cable is firmly connected to the main board.
- 3 Check all wires to/from sensor.

### **Halogen lights are not functioning:**

- 1 Check power supply cable if it is connected.
- 2 Check power supply wire integrity.
- 3 Check connector plug if halogen did not come lose.
- 4 Check if halogen is not burned by swapping it with a new one (12V 20W).

**Computer power supply is not functioning:**

- 1 Check if power supply cable is plugged in securely.

**Power supply is refusing to work:**

- 2 Check if “car” fuse in power supply is not burned 7.5A (brown).
- 3 Check if transformer cable is correctly hooked up to power supply socket.

**Machine is not starting:**

- 1 Check power cable fuse 5A placed in feeding module (filter).
- 2 Check if filter is not damaged.

**Counter is showing Err:**

- 1 Check if mechanical counter did not come loose (then turn the machine OFF and ON).

**Bill Acceptor is not functioning:**

- 2 Check if power supply cable is hooked up to main board (J3).
- 3 Check if cable from bill acceptor is correctly hooked up.
- 4 Check acceptor settings using switches from 1-8 set it at ON 7, and from 1-4 set ON 3 & 4.

**Sound is not working:**

- 1 Check if it is not at low volume or mute (R362)
- 2 Check if cable is correctly connected to the main board.
- 3 Check if cable to speaker is correctly connected.

**Red diode active on main board:**

Usually caused by circuit being shorted at scale bulb array, check all cables for potential shortage.

# 10. SETTINGS

## Main Board Layout (Back Side)

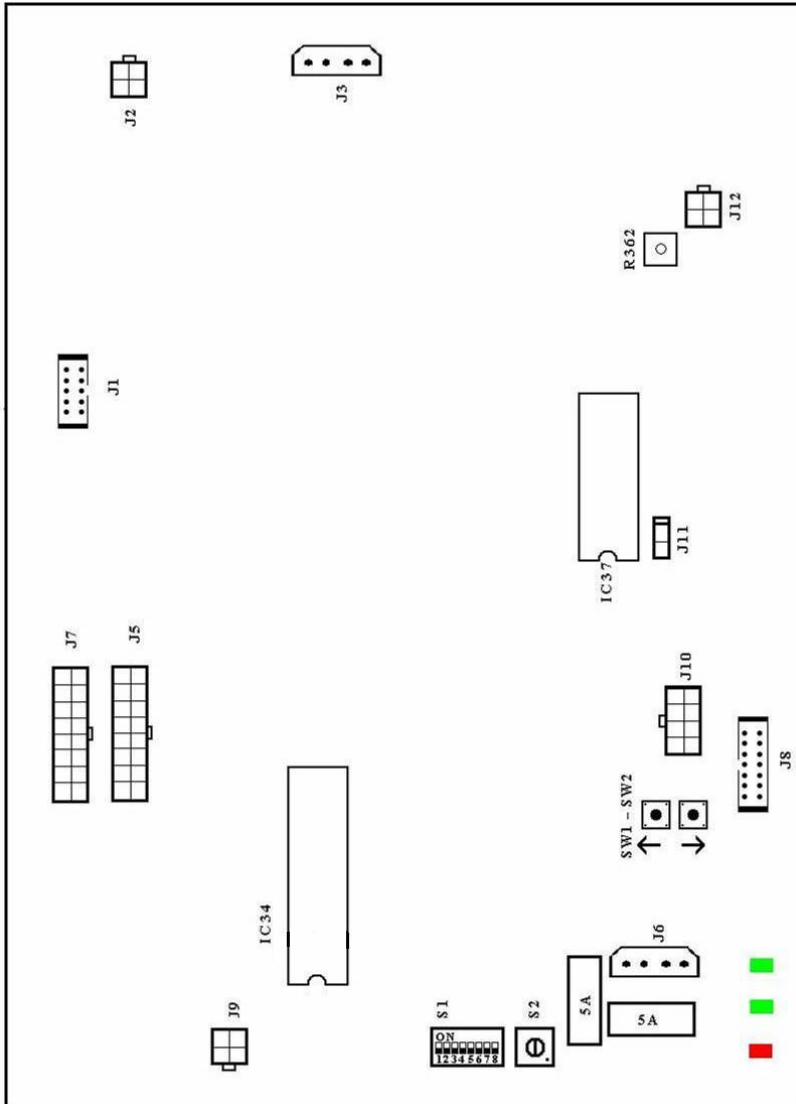

Drawing #1

## **LIST OF CONNECTORS**

**J1 –connector for coin acceptor**

**J2 –connector for bill acceptor**

**J3 –connector for power supply to bill acceptor (12V supplied by AC power supply)**

**J7 & J5 – front panel backlight**

**J6 – connector for main board power supply (12V supplied by AC power supply)**

**J8 – connector for power supply**

**J9 – sensor connector**

**J10 – connector for button Service Key - optional**

**J11 – connector for mechanical counter**

**J12 – connector for speaker**

**S1 – service setting switch**

**S2 – step potentiometer for setting sensor sensitivity (0 – min, 9 - max) – difficulty of the game**

**SW1 & SW2 – help buttons (top)**

**R362 – potentiometer for volume control**

**IC37 – speak synthesizer**

**IC34 – main processor socket**

## **Dip Switch 1-8 (S1)**

THE BLUE (BLACK OR RED) SWITCH BOX WITH 8 SWITCHES. THIS SWITCH BOX IS LOCATED ON THE LEFT SIDE OF THE MAIN CIRCUIT BOARD. TO PROGRAM SWITCH #1 MUST BE SET TO “ON” POSITION.

PUSH BUTTONS SW1 ↑ OR SW2 ↓. THEY ARE LOCATED IN THE LOWER LEFT PART OF THE MAIN CIRCUIT BOARD.

DURING REGULAR USAGE OF THE KICKER AND KICK-OF ALL OF THE SWITCHES MUST BE IN “OFF” POSITION (LEFT SIDE).

## **Switch #1**

SERVICE KEY. PLEASE USE BUTTONS SW1 ↑ OR SW2 ↓ FOR FINDING THE RIGHT PROGRAM P01-P20. DESCRIPTIONS FOR EACH PROGRAM ARE LISTED BELOW. SERVICE KEY - AFTER PUSHING SMALL BUTTONS ↑ YOU WILL SEE P01-P20 ON THE MAIN DISPLAY (THE BIGGEST).

REMEMBER FOR SOME SETTINGS YOU NEED TO USE SERVICE BUTTON PLACED ON THE RIGHT SIDE OF SIDE POWER SUPPLY (SMALL RED BUTTOM).

### **P01**

TEMPORARY COUNTER OF POINTS. YOU CAN RESET IT TO 0000 BY PUSHING AND HOLDING THE SERVICE BUTTON FOR 10 SECONDS.

### **P02**

COUNTER OF POINTS. THIS IS LIFE LONG - NOT ERASEABLE.

### **P03**

COUNTER OF THE FREE HITS WHICH YOU ACTIVATE BY DIP SWITCH # 2 FOR "ON" POSITION.

### **P04**

COUNTER OF THE POINTS FOR ONE CREDIT, ANOTHER WORDS HOW MANY POINTS ARE NEEDED FOR ONE CREDIT. THE POINTS ARE SET BY THE SERVICE BUTTON.

Example: 1 game (credit) is worth four points, so the P04 will be set to 4.

### **P05**

YOU CAN ADJUST ADDITIONAL CREDITS FOR SOME BILL OR COINS.

USING THE SERVICE BUTTON YOU CAN ADJUST FOR HOW MANY POINTS (5\$, 10\$, 20\$, 50\$) YOU WILL RECEIVE DESIRE NUMBER OF CREDITS WHICH YOU SET BY SERVICE BUTTON.

Example USA: you want to set 8 credits (kicks) for 5\$, you should set 20-8.

Example Europe: 5 credits for 2 EUR0, you should set 4-5.

#### **P06**

YOU CAN ADJUST ADDITIONAL CREDITS FOR SOME BILL OR COINS, ANOTHER THAN IN P05, **BUT ALWAYS FOR BIGGER VALUE OF THE BILL OR COIN THAN IN P05.**

WITH THE SERVICE BUTTON YOU CAN ADJUST FOR HOW MANY POINTS (5\$, 10\$, 20\$, 50\$) YOU WILL RECEIVE DESIRE NUMBER OF CREDITS WHICH YOU SET BY SERVICE BUTTON.

Example: you want give for 5\$-8 (credits) kicks, you should set 20-8.  
you want give for 10\$-18 (credits) kicks, you should set 40-18.

#### **P07**

TESTING OF THE SENSOR. IF IN KICK OFF MACHINE BALL IS IN THE DOWN POSITION - ON THE DISPLAY YOU WILL SEE - "LO". BALL IS IN THE UP POSITION - DISPLAY SHOWS "HI".

TESTING OF THE SENSOR. IF IN KICKER MACHINE BALL IS IN THE LEFT POSITION - ON THE DISPLAY YOU WILL SEE - "LO". BALL IS IN THE RIGHT POSITION - DISPLAY SHOWS "HI". THIS IS USED FOR DIAGNOSTIC ONLY.

#### **P08**

YOU CAN SET THE BEST SCORE UNBEATABLE RECORD WHICH WILL BE ON THE DISPLAY FOR **POWER** ONLY.

PLAYERS WILL NEVER BE ABLE TO RECEIVE HIGHER SCORE.

THIS SET UP YOU CAN MAKE BETWEEN 900 AND 990. THE VALUE OF THE BEST SCORE YOU CAN ADJUST BY USING SERVICE BUTONS. AFTER YOU SET THE DESIRE RECORD YOU MUST TURN "ON" SWITCH # 5.

**IMPORTANT: AFTER YOU SET THE RECORD AND PUT SWITCH #5 TO "ON" POSITION YOU MUST TURN OFF THE MACHINE FOR 5 SECONDS.**

#### **P09**

IS USED FOR DIFFERENT SETTINGS OF THE COIN ACCEPTOR, FOR EXAMPLE: 0-USA, 1-CANADA.

- P10**  
PARAMETER USED BY FACTORY. DEFAULT SETTINGS IS 0.
- P11**  
TICKET DISPENSER 1 - "ON", 0 - "OFF".
- P12**  
HOW MANY TICKETS FOR 1 CREDIT (RANGE FROM 0-5).
- P13**  
HOW MANY TICKETS FOR THE RECORD (RANGE FROM 0-20).
- P14**  
"BREAKING POINT"- BP  
SETTING THAT WOULD ENABLE THE TICKET DISPENSER TO  
START GIVING OUT THE TICKETS (RANGE FROM 0-990).  
FACTORY SETTING IS "0".
- P15**  
HOW MANY TICKETS WILL BE GIVEN OUT AFTER  
REACHING THE "BREAKING POINT" AS THE FIRST VALUE  
(RANGE FROM 0-20). FACTORY SETTING "0".
- P16**  
POINT INCREMENT, ANOTHER WORDS WHAT IS THE  
INCREMENT WHEN THE NEXT TICKET/S WILL BE RELEASED  
(RANGE FROM 10-100). FACTORY SETTING IS "40".
- P17**  
NUMBER OF TICKETS GIVEN OUT AFTER REACHING EACH  
POINT INCREMENT – SET IN P16. FACTORY SETTING IS "1".

**P18**

**COUNTER OF RELEASED TICKETS.**

**BELOW ARE TWO EXAMPLES.**

RESULT ON DISPLAY	TICKETS		RESULT ON DISPLAY	TICKETS
1	0		1	0
40	1		40	0
80	2		80	0
120	3		120	0
160	4		160	0
200	5		200	0
240	6		240	0
280	7		280	0
320	8		320	0
360	9		360	0
400	10		400	0
440	11		440	0
480	12		480	0
520	13		520	0
560	14		560	0
600	15		600	10
640	16		640	12
680	17		680	14
720	18		720	16
760	19		760	18
800	20		800	20
840	21		840	22
880	22		880	24
920	23		920	26
960	24		960	28
P14 = TICKET = 0			P14 = TICKET = 600	
P15 = TICKET= 0			P15 = TICKET = 10	
P16 = TICKET=40			P16 = TICKET = 40	
P17 = TICKET= 1			P17 = TICKET = 2	

**P19**

YOU CAN SET 0-10 BONUS CREDITS FOR A NEW RECORD BY USING THE SERVICE BUTTON.

**P20**

YOU CAN CLEAR THE CREDITS BY PUSHING THE SERVICE BUTTON.

**P21**

IT SHOW HOW MUCH COINS/NOTES WERE INSERTED WHILE MECHANICAL COUNTER WAS OFF.

**P22**

SHOWS HOW MANY TIMES THE TOP SCORE/RECORD WAS BROKEN.

**Switch #2**

WHEN "ON" MACHINE IS SET FOR FREE KICK.

**Switch #3**

IF ON "DEMO" WILL PLAY EVERY 2 MINUTES, WHEN THE MACHINE IS NOT USED. IF "OFF" THE SOUND IS TURNED OFF.

**Switch #4**

WHEN "ON" THE HIGHEST SCORE FOR EACH GAME WILL BE RESET. AFTER YOU PUSH THE START BUTTON. WHEN "OFF" THE TOP SCORES WILL STAY DISPLAYED.

**Switch #5**

WHEN "ON" YOU WILL ACTIVATE UNATTAINABLE RECORD WHICH YOU MUST SET BEFORE IN P08 (SERVICE KEY).  
REMEMBER: TO ACTIVATE THIS RECORD YOU MUST TURN OFF FOR 5 SECONDS AND TURN ON THE MACHINE.

**Switch #6**

**NOT USED.**

**Switch #7**

IF THE SWITCH IS ON, RESULTS ARE SHOWN IN YARDS (In Kick-Off only).

**Switch #8**

NOT USED.

**Main Board Layout (Front)**

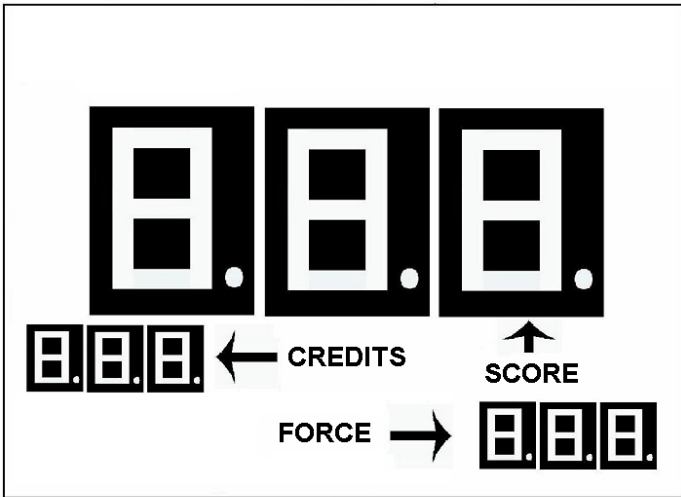

Drawing #2

## Power Supply Layout:

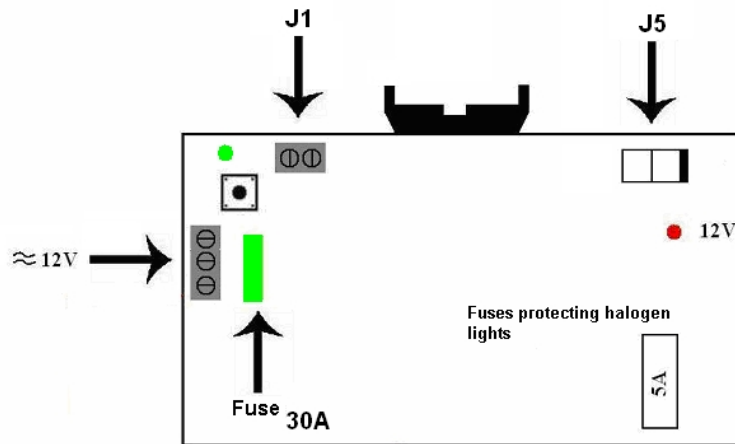

Drawing #3

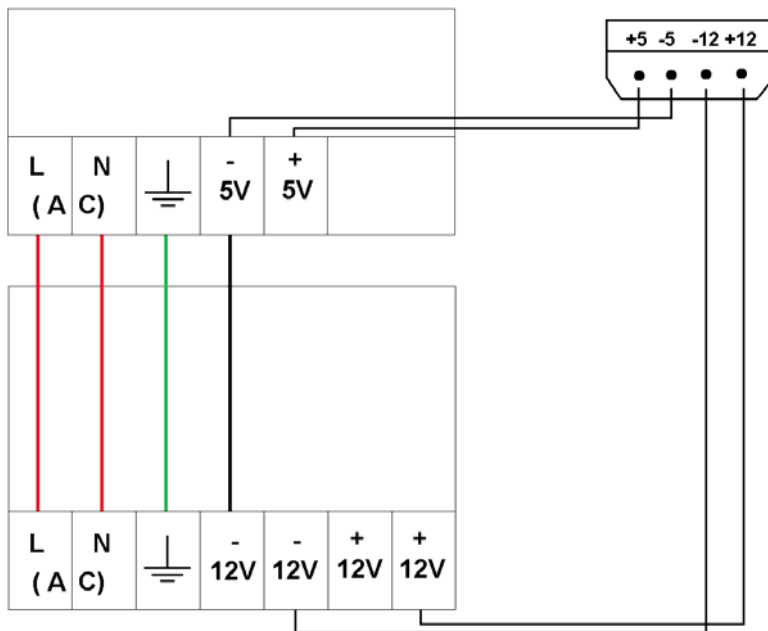

Drawing #4

## Mechanical counter



- 2 – red wire from mechanical counter
- 1 – black wire from mechanical counter

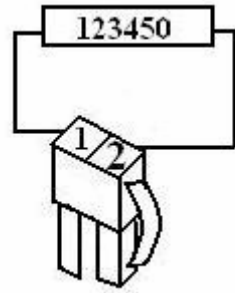

Drawing #5

## Sensor

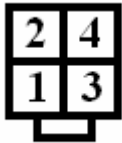

- 1- Emitter
- 2- Cathode
- 3- Anode
- 4- Collector

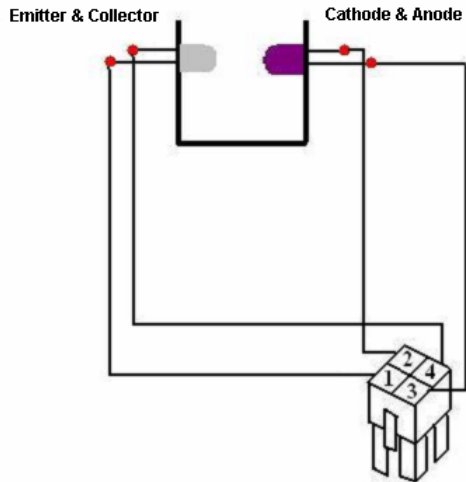

Drawing #6

**Buttons Start & Game**

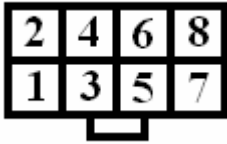

- 1 & 2 – bulbs lighting button
- 5 & 6 – service button
- 7 & 8 – Start button

**Speaker**

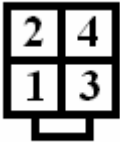

- 1 - speaker
- 2 - speaker
- 3 - unused
- 4 - unused

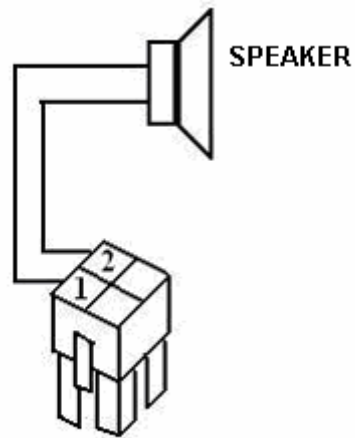

Drawing #6

**J5 In Kicker Machine**

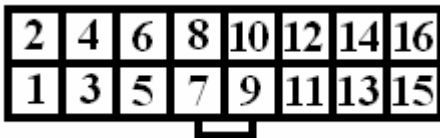

- 6 – Eyes Led’s (-)
- 5 – Eyes Led’s (+)

**J5 In Kick Off machine**

2	4	6	8	10	12	14	16
1	3	5	7	9	11	13	15

- 6 – Eyes Led's (-)
- 5 – Eyes Led's (+)
- 4 – Led's (-)
- 3 – Led's (+)
- 2 – Led's (-)
- 1 – Led's (+)

**J7 In Kick Off machine**

2	4	6	8	10	12	14	16
1	3	5	7	9	11	13	15

- 8 – Eyes Led's (-)
- 7 – Eyes Led's (+)
- 6 – Led's (-)
- 5 – Led's (+)
- 4 – Led's (-)
- 3 – Led's (+)

## Paper Money Depositor

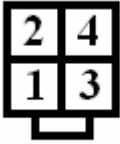

1 – Credit relay (Common) normally purple. Pin#8 at the ICT connector

2 – +12V (Power) normally red. Pin#5 at the ICT connector

3 – GND (Power) normally orange. Pin# 9 at the ICT connector

4 – Credit relay (N.O) normally blue. Pin# 7 at the ICT connector

### **11. SPARE PARTS AND EQUIPMENT**

- leveling legs 4 pieces
- punching bag pump 1 piece
- bladder 1 piece

## 12. STEP BY STEP SETUP AND MAINTENANCE INSTRUCTIONS

### **HOW TO ACCESS QUICKLY RESETABLE (P01) AND NOT RESETABLE (P02) MONEY COUNTERS**

P01 and P02 counters can be checked (at the same time) without going into service program, by pressing switch SW1 ↑. The SW1 switch is located in the lower left part of the main board, right above ribbon cable connecting main board with side power supply (small board). The displayed numbers will appear for 30 seconds. During that time counter P01 can be reset by pressing and holding switch SW1 for 3 seconds (after resetting machine will switch to regular work mode).

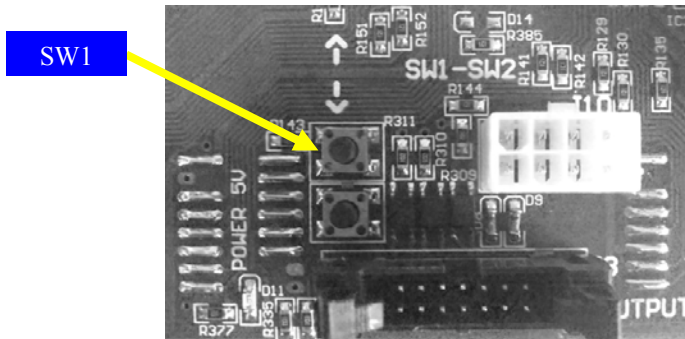

## HOW TO SET-UP PRICE OF THE GAME PLAY.

Enter the settings mode by powering up the machine and switching DIP switch #1 to ON position.

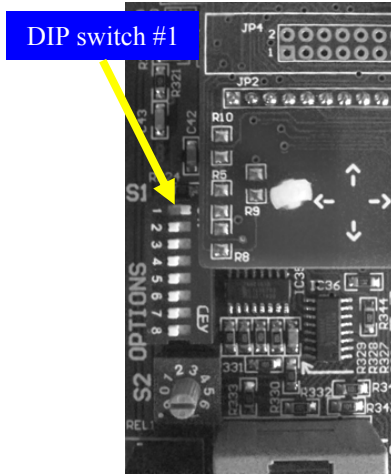

The main display should now indicate the settings mode with 'P 1' as shown.



Press the SW1 button repeatedly on the main board until the main display reads 'P 4'. If you get too far on this menu you can always get back with the SW2 button.

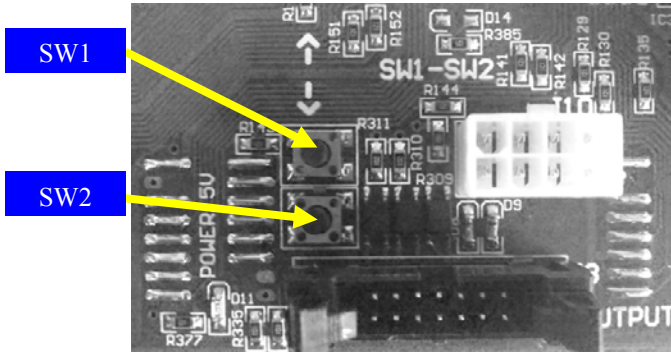

Now you can modify the setting to set-up the price of the game play (If one game credit is to cost \$1 the setting would then be 4 -1, meaning that 4 quarters equals one punch). There is one number you must set here and this is done by the machine's **START** button in the front. After you are done the display should look like the following picture if you chose these settings.

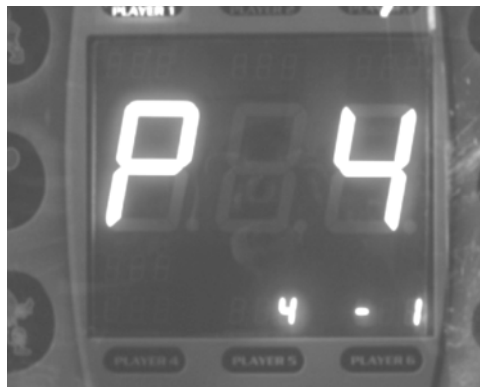

To leave the settings mode simply turn the DIP switch #1 to off (left) position.  
The machine should reset and be ready to go.

## HOW TO SET UP BONUS POINTS

Enter the settings mode by powering up the machine and switching DIP switch #1 to ON position.

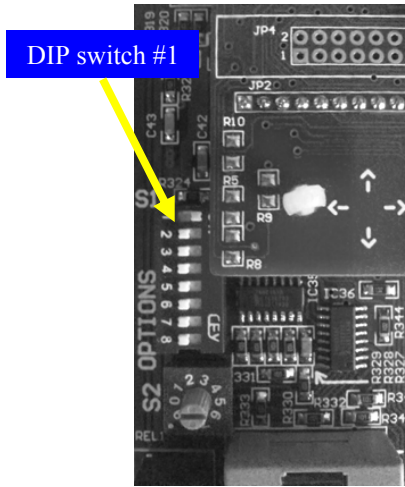

The main display should now indicate the settings mode with 'P 1' as shown.



Press the **SW1** button repeatedly on the main board until the main display reads 'P 5'. If you get too far on this menu you can always get back with the **SW2** button.

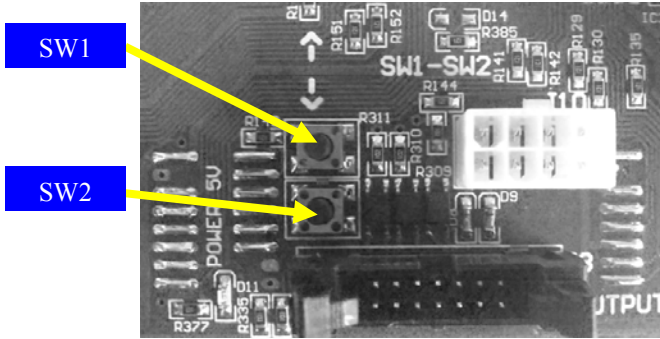

This setting corresponds to the number of credits given when a set dollar amount is put in the machine. For example: you want to set 8 credits (punches) for \$5 ( $5 \times 4 = 20$  quarters), you should adjust this setting to indicate 20-8 as shown.



The values can be set using **START** and **GAME** buttons (GAME button is placed on the main board). As shown, **START** sets the left value and **GAME** sets the right value. Repeat the procedure for 'P 6' but remember to set the bonus for a larger amount of money than in 'P 5'. Example could be for \$10, 20 credits ( $10 \times 4 = 40$ , so the setting is 40-20). If you get too far while increasing these values you must continue going up to 100 before you again end up at single 0.

To leave the settings mode simply turn the DIP switch #1 to off (left) position. The machine should reset and be ready to go.

## **HOW TO RESET HIGH SCORES MANUALLY**

If you feel the score on the game reached an unbeatable number you can reset this score to the default value (650). Enter the settings mode by powering up the machine and switching DIP switch #4 to **ON** position.

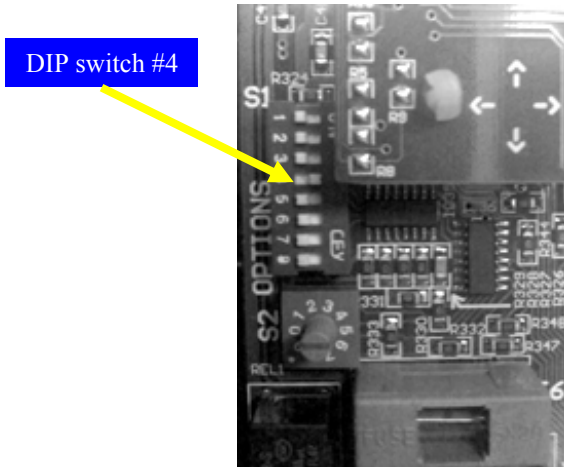

You will not see any changes on the display and the game will remain in playable mode. This is why it is important to remember to switch the machine back from this mode when done resetting. Next, press and hold the **START** button on the machine for about 10 seconds. When the score resets on the main display then release the **START** button and put DIP switch #4 back to **OFF** position.

## HOW TO ERASE CREDITS

Erasing the game's credits can be done with the following procedure. Enter the settings mode by powering up the machine and switching DIP switch #1 to ON position.

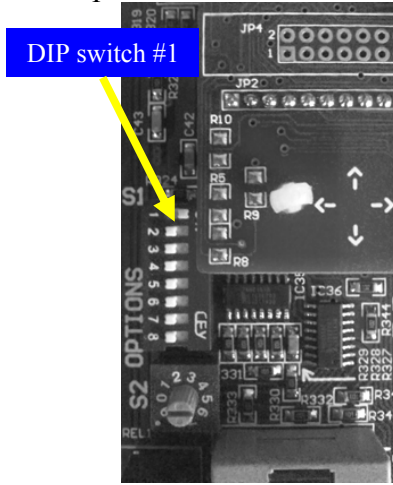

The main display should now indicate the settings mode with 'P 1' as shown.



Press the **SW1** button repeatedly on the main board until the main display reads 'P20'. If you get too far on this menu you can always get back with the **SW2** button.

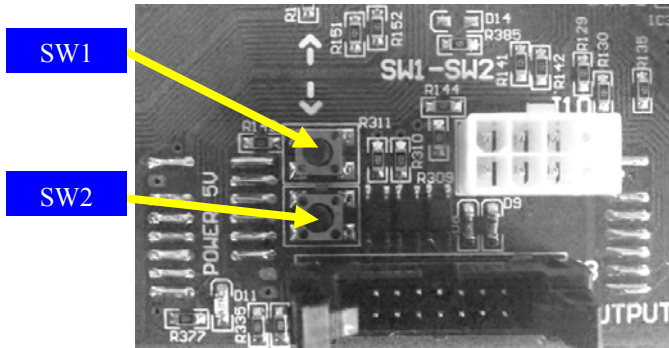

Press the **START** button located in the front of the game. When finished don't forget to set DIP switch #1 back to OFF position.

## **HOW TO CHANGE THE FUSE IN THE MAIN SWITCH**

Locate the power cord connection on the back of the machine. The fuse can be found hidden between the power cord socket and the main ON/OFF switch. In order to replace it use a flat screwdriver to pry open the fuse holder and pull it out. Replace it with a new one.



## HOW TO CHECK THE SOLENOID

Proper operation of the solenoid can be verified by releasing the kicking bag electronically. This can be done by pushing the release button located on the side of the power supply (not the main board). Power up the machine and press this button. If the ball is released the solenoid is working.



If the ball does not come out there may be a problem with the solenoid. Remove the two solenoid wires connected to the power supply circuit board. Unscrew the two terminals and pull these wires out.

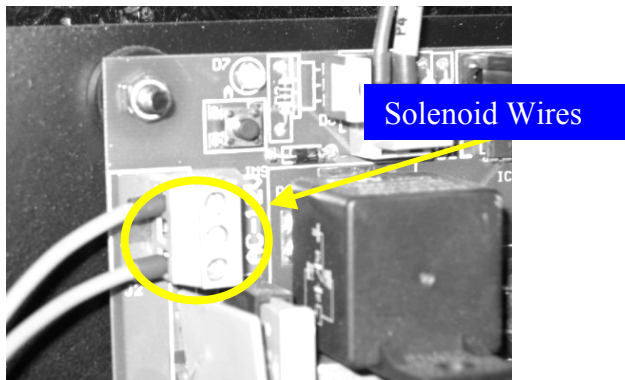

Check resistance on these two terminals with a multi-meter. The resistance should be very low around 0.5  $\Omega$ . If your meter shows overload or infinite resistance the solenoid coil may be damaged. In that case replacing the solenoid is necessary.

The solenoid can be evaluated in another way if for example you do not have a multi-meter handy. This also involves unscrewing the two terminals and pulling out the two wires. Instead of measuring the resistance as described above make a temporary connection with direct 12 V supply by touching the two wires onto the input voltage terminal as shown in the picture below.

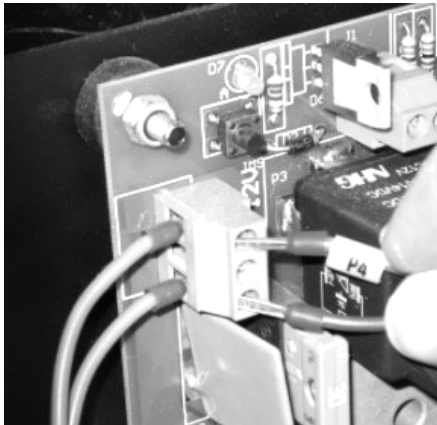

## **HOW TO CHANGE START BUTTON**

### ILLUMINATED START BUTTON

The illuminated START button is connected with both, the white and the red connectors. The red connectors are stick on the sides, while the whites are on the back and upper side of the button. See the photo below for the proper connection.

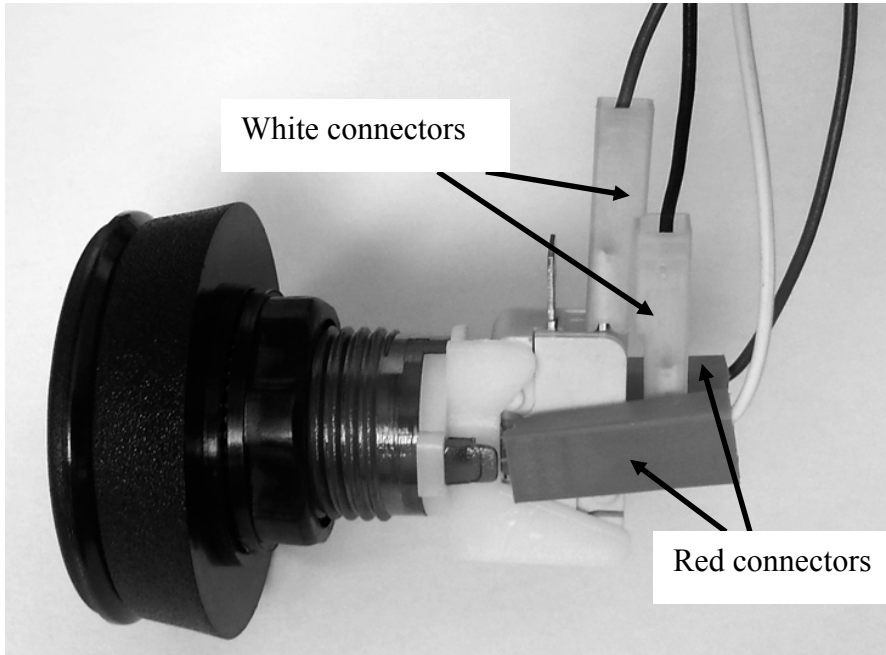

The red connectors are for the lights, the white connectors are for the button itself.

### Replacement procedure.

Unscrew the button (its nut). Unlock the white part of the button. Disconnect all wires. Pull out the button from the assembly hole. Replace with the new button using the above instructions.



